

# LMH Two Side Cut Flange Type (Metric Dimension)

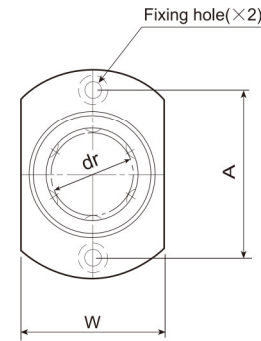

LMH 13 or less

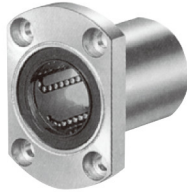
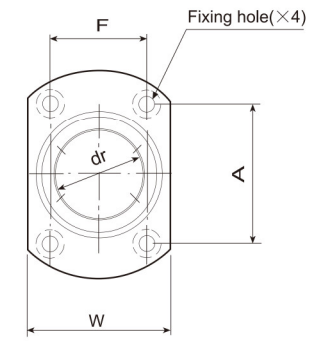
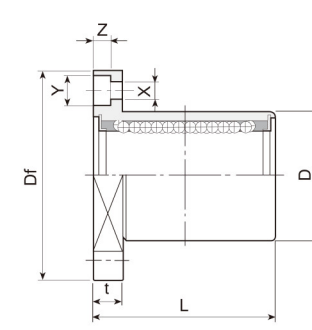

LMH 16 or more

Nominal shaft diameter mm	Model No.	Main dimensions and tolerance						
	LMH...UU	dr		D		L		
		mm	Tolerance μm	mm	Tolerance μm	mm	Tolerance μm	
6	LMH 6UU	6	0	12	0	19	0	
8	LMH 8UU	8		15	-13	24	-200	
10	LMH 10UU	10		19	0	29	0	
12	LMH 12UU	12		21		30		
13	LMH 13UU	13	-9	23	-16	32	0	
16	LMH 16UU	16		28		37	-200	
20	LMH 20UU	20	0	32	0	42	0	
25	LMH 25UU	25		40		-19		59
30	LMH 30UU	30		45		-19		64

Main dimensions and tolerance								Eccentricity μm	Squariness μm	Basic load rating		Weight g	Nominal shaft diameter mm
Flange										dynamic C(kgf)	static Co(kgf)		
Df mm	W mm	t mm	A mm	F mm	X mm	Y mm	Z mm						
28	18	5	20	—	3.5	6	3.1	12	12	21	27	21	6
32	21	5	24	—	3.5	6	3.1			28	40	33	8
40	25	6	29	—	4.5	7.5	4.1			38	56	64	10
42	27	6	32	—	4.5	7.5	4.1			52	80	68	12
43	29	6	33	—	4.5	7.5	4.1			52	80	81	13
48	34	6	31	22	4.5	7.5	4.1			79	120	112	16
54	38	8	36	24	5.5	9	5.1	15	15	90	140	167	20
62	46	8	40	32	5.5	9	5.1			100	160	325	25
74	51	10	49	35	6.6	11	6.1			160	279	388	30