

SCREW/SPLINE

RLBF Series Specifications

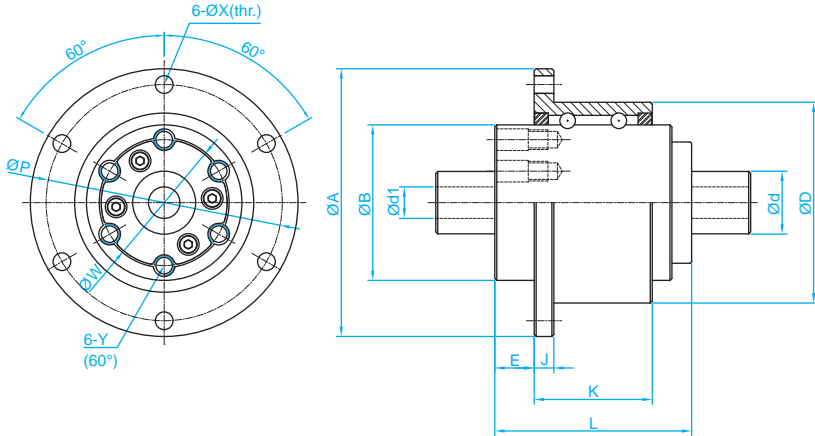

Unit : mm

Model No.	d	d1	Row	Support Bearing Load Rating		Spline Nut Dimension											Ball Spline Load Rating	
				Ca (kgf)	Coa (kgf)	D	A	B	L	E	J	K	P	X	W	Y	Ca (kgf)	Coa (kgf)
RLBF016	16	8	2	746	1597	52 ⁰ _{-0.007}	68	39.5 ⁰ _{-0.025}	50	10	5	30	60	4.5	32	M5	545	849
RLBF020	20	10	2	1011	2138	56 ⁰ _{-0.007}	72	43.5 ⁰ _{-0.025}	63	12	6	42	64	4.5	36	M5	736	1124
RLBF025	25	15	4	1558	4616	62 ⁰ _{-0.007}	78	53 ⁰ _{-0.03}	71	13	6	49	70	4.5	45	M6	1003	1593
RLBF032	32	16	4	2087	5586	80 ⁰ _{-0.007}	105	65.5 ⁰ _{-0.03}	80	17	9	54	91	6.6	55	M6	1324	2251
RLBF040	40	20	4	3141	8705	100 ⁰ _{-0.008}	130	79.5 ⁰ _{-0.03}	100	23	11	63	113	9	68	M6	2972	4033
RLBF050	50	26	4	4317	12585	120 ⁰ _{-0.008}	156	99.5 ⁰ _{-0.035}	125	25	12	87	136	11	85	M10	4086	5615

D

Rotary Ball Screw/Spline